

INFI-SHIELD® UNI-BAND

SPECIFICATION
Patent Pending

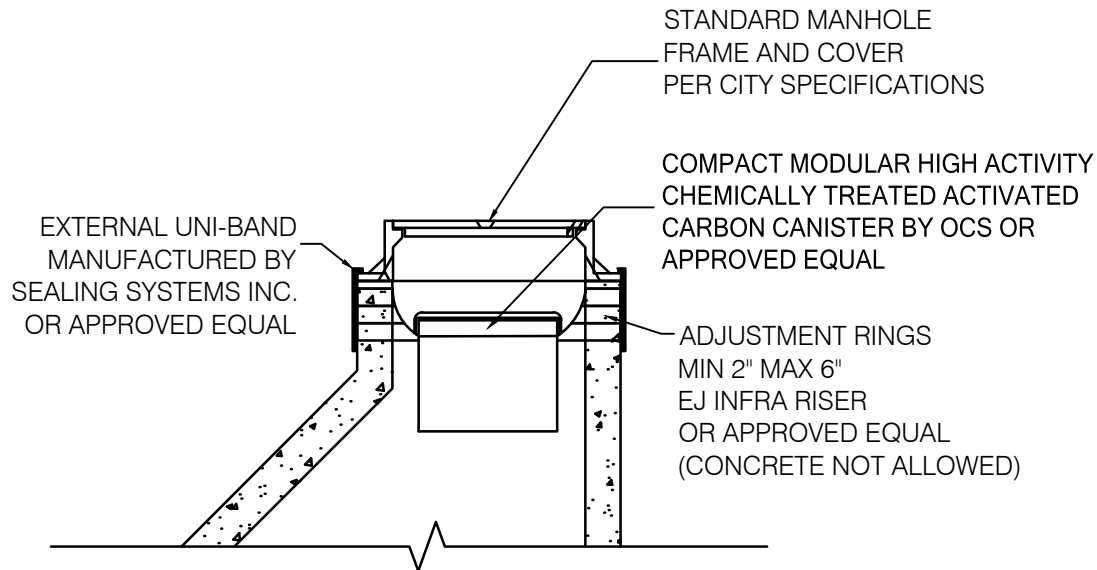

The seal shall be continuous seamless band made of high quality (EPDM) rubber with minimum thickness of 65 mils. There shall be preformed L shaped corner molded into the top of the seal. The top section and side section will extend from from the L shaped corner generally 90-degree angle to each other. Wherein the seal is preformed in substantially the same shape as attached to the manhole structure. There shall be a 2" to 3" wide strip of butyl mastic attached to the underside of top section of the seal. There shall be a 2" strip of wide butyl mastic attached to the inside of the side section at the bottom of the seal. The mastic shall be non-hardening butyl rubber sealant, with a minimum thickness of 1/8" and shall seal to the cone/top of the manhole section and over the flange of the casting frame. An aerosol primer shall be used to enhance the bond strength of the seal to the structure

OCS CANISTER

Scope: Where indicated on the plans an Odor Control Manhole Insert shall be placed between the manhole frame and lid.

Spec: Manhole Insert and Canister shall be HDPE ordered specifically to fit specified manhole frame and cover by submitting order form and drawing of casting to manufacturer. Insert shall have seal attached to outer ring to seal between frame and insert. Canister shall be vented on bottom to allow H₂S to rise into carbon bed and eliminate H₂S odor. Canister shall be filled with Darco Carbon specially formulated to remove H₂S from air in MH.

Manufacturers:

Odor Control Specialties, North Kansas City, Missouri
phone: 877-279-4027
www.oc-online.net



120 E. 15th Avenue
N. Kansas City, MO 64116
(ph) 877-279-40CS (027)
(fx) 816-746-8264

OC-ONLINE.NET



ODOR CONTROL MANHOLE INSERT